

# VTB 200 Butterfly valves



## Address

<http://www.vapo.nl>

Vapo Techniek BV  
Esp 258  
5633 AC Eindhoven  
Netherlands

T: +31(0)40 248 10 00  
F: +31(0)40 248 10 40  
E: [vapo@vapo.nl](mailto:vapo@vapo.nl)

<b>Table of Contents</b>	
General information	3
Operational data	3
Options	3
Seat Materials and their applications	
Kv-Values	3
VTB200 Wafer DN32/40-300	4
Materials	4
Dimensions [mm]	4
VTB200 LUG DN40-300	5
VTB200 Gearbox DN50-DN300	6
VTB200 Wafer DN350-DN450	6
Materials	6
Dimensions [mm]	7
VTB200 DN500-DN1200	8
Materials	8
Dimensions [mm]	9
VTB200 with pneumatic actuator DN50-DN300	10
VTB200 with pneumatic actuator DN350-DN600	11
Assembly and disassembly instructions	12
Assembly	12
Disassembly	12
Removing the valve from the pipeline	12
Installing the valve in an existing pipeline	
Installing the valve in a new pipeline	13
Additional installation information	14

## TRADEMARKS

Following brand names are Dupont registered trademarks:

- Kalrez®
- Viton®
- Teflon®
- Hypalon®
- BUNA-N®

## DISCLAIMER

Vapo Techniek BV has done its utmost to ensure that all data in this documentation is correct. However, Vapo Techniek BV accepts no responsibility for possible problems caused by mistakes in this documentation.

# VTB200

## General information

- Butterfly valve, which has an Seat and Disc which will get in contact with the media.
- Installation in both flow directions possible.
- Simple installation and maintenance, no necessary extra packing needed for assemble between flanges.
- Body is epoxy painted against corrosion.
- Complete tight up to 20 barg.
- Suitable for direct mounting pneumatic or electric actuators.

## Specifications

- Wafer type or Lug Type with threaded holes.
- Face to Face standard DIN3202-3 K1.
- Seating EPDM / Buna-N.
- Pressure class PN10/16 - ASA150.
- ISO5211 Flange connection for direct mounting of actuators up to DN300.
- Secured stem.

## Operational data

Working pressure: max. 20 barg, depending of temperature. not suitable for Vacuum-Systems.

Temperature: depending of Seat material.

## Options

- Seating in PTFE.
- Disc in Alu-bronze.
- Electric and pneumatic actuators



## Seat materials and their applications.

Material	Contents	General applications	Temperature	Not to be used
EPDM	Ethylene Propylene Terpolimeer	Water, Steam, Seawater, Phosphates, Esters, Ketones	-35° C up to 110° C	Hydrocarbons, Oil, Fats, Dry Air
Buna-N	Copolymer of Butadien and Acrylonitril	Water, Air, Alcohol, Natural Gas, Petroleum/Gasoil (Hydrocarbons with less then 40% Aromatics)	-12° C up to 85° C	Solvents, Benzene, Xylene

## Kv-Values

$$Kv=Cv*0.864881.$$

DN	20°	30°	40°	50°	60°	70°	80°	90°
32/40 1 1/4"- 1 1/2"	2.6	6.1	10.4	19	34.6	54	74	82
50 2"	4.3	10.4	20.8	38.9	55	78	108	117
65 2 1/2"	6.9	17.3	29.4	56	85	125	176	190
80 3"	10.4	19	33.7	61	100	158	238	261
100 4"	14.7	31.1	67	120	199	315	472	519
125 5"	25.1	53	115	205	339	536	804	884
150 6"	38.9	82	177	317	523	829	1243	1366
200 8"	77	163	353	629	1040	1646	2468	2712
250 10"	131	277	600	1070	1770	2802	4202	4618
300 12"	202	428	927	1653	2735	4329	6493	7135
350 14"	336	618	1340	2388	3951	6253	9379	10307
400 16"	401	850	1842	3284	5433	8599	13898	14174
450 18"	532	1126	2441	4349	7196	11389	17083	18772
500 20"	684	1448	3138	5591	9252	14643	21965	24133
600 24"	1057	2237	4848	8639	14295	22623	33934	37290
700 28"	1293	2824	5930	10573	17488	27676	41514	45620
800 32"	1699	3323	7783	13877	22953	36325	54488	59876
900 36"	2343	4625	10793	19164	31697	50163	75245	82686
1000 40"	2909	5740	13343	23789	39348	62271	93407	102645

# VTB200 Wafer DN32/40-300

## Materials

Item	Description	Materials
1	Body	GG25
2	Disc	304SS      316SS
3	Stem	416SS
4	Seat ring	EPDM or Buna-N
5	Bushing	PTFE-Fiberglass
6	O-ring	EPDM
7	Circlips	Steel
8	Washer	Steel
9	Sector plate	SS
10	Lever	Aluminium
11	Bolt	SS
12	Nut	SS
13	Washer	SS

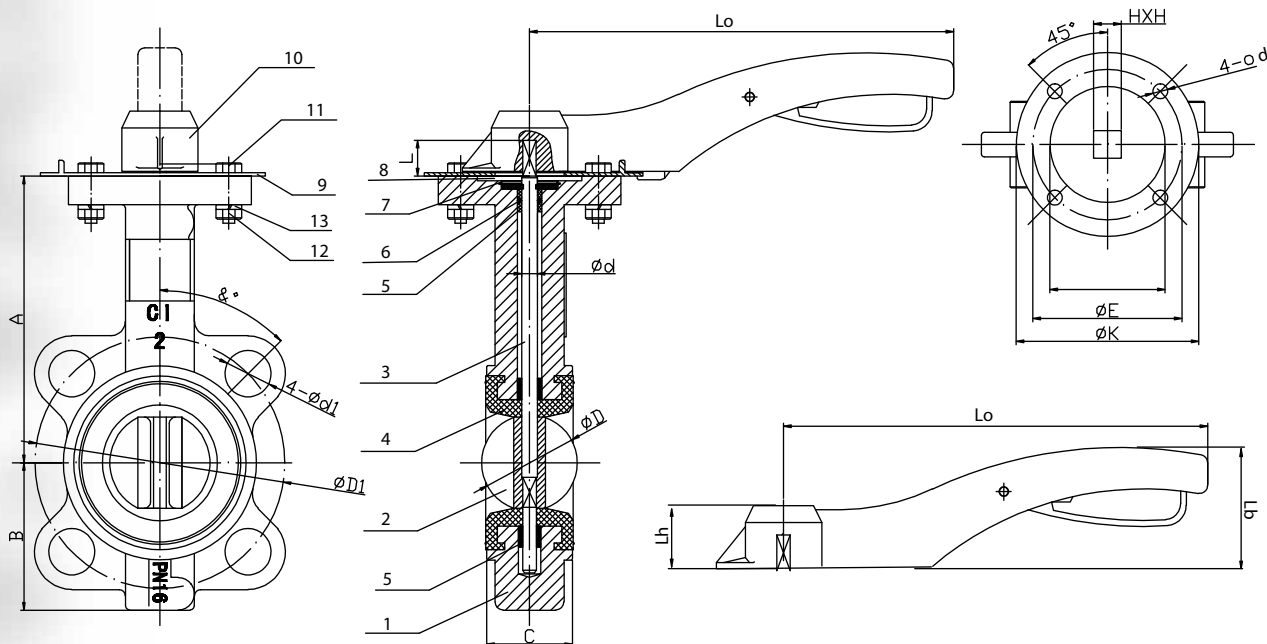

## Dimensions [mm]

DN	A	B	C	D	L	Lo	K	E	H	d	Lh	Lb	Weight [kg] with lever
32/40	130	67	43	40.9	30	170	70	F05(50)	9	7	34	75	2.9
50	140	71	42	52.7	30	170	70	F05(50)	11	7	38	85	3.2
65	152	85	45	64.4	30	170	70	F05(50)	11	7	38	85	4.3
80	159	96	46	74.7	30	170	70	F05(50)	11	10	38	85	5.6
100	178	115	52	104	30	170	70	F05(50)	11	10	38	85	7.7
125	191	129	55	123.3	30	220	90	F07(70)	14	10	38	85	8.5
150	204	140	56	155.6	30	220	90	F07(70)	14	10	38	85	14.6
200	238	173	61	202.5	40	265	90	F07(70)	17	12	48	100	20.6
250	270	210	66	250.5	40	350	125	F10(102)	22	12	44	100	34.8
300	315	234	77	301.5	40	350	125	F10(102)	22	12	44	100	46.9

# VTB200 LUG DN40-300

## Materials

Item	Description	Materials	
1	Body	GG25	
2	Disc	304SS	316SS
3	Stem	416SS	
4	Seat ring	EPDM or Buna-N	
5	Bushing	PTFE-Fiberglass	
6	O-ring	EPDM	
7	Circlips	Steel	
8	Washer	Steel	
9	Sector plate	SS	
10	Lever	Aluminium	
11	Bolt	SS	
12	Nut	SS	
13	Washer	SS	

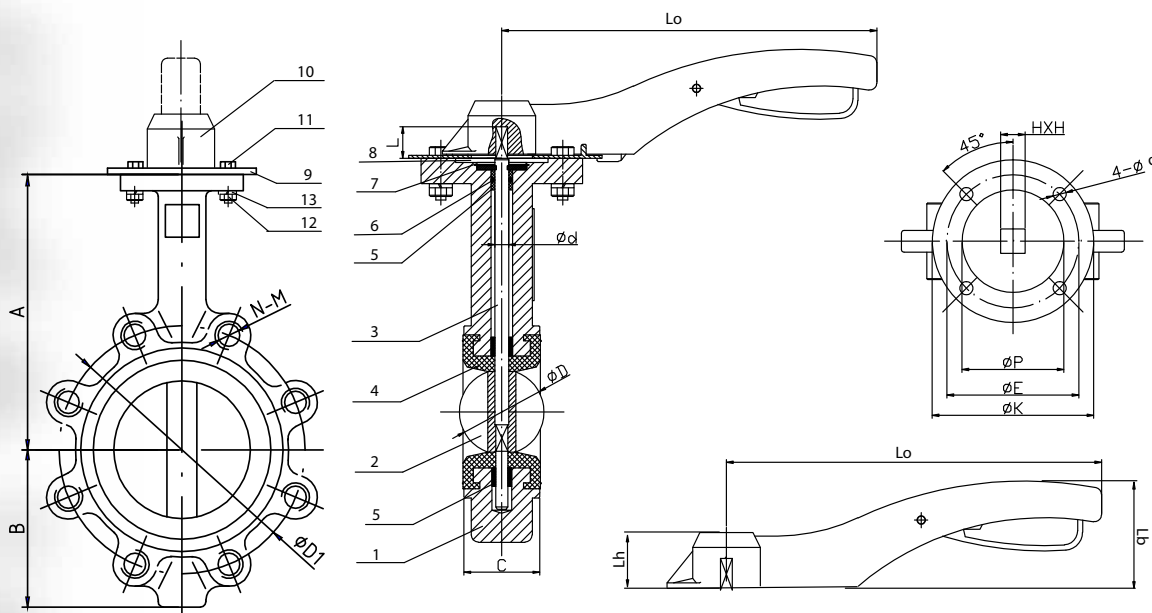

## Dimensions [mm]

DN	A	B	C	D	L	Lo	K	E	H	d	Lh	Lb	Weight [kg] with lever
50	140	71	42	52.7	30	170	90	F05(50)	11	7	38	85	3.2
65	152	85	45	64.4	30	170	90	F05(50)	11	7	38	85	4.3
80	159	96	46	74.7	30	170	90	F05(50)	11	10	38	85	5.6
100	178	115	52	104	30	170	90	F05(50)	11	10	38	85	7.7
125	191	129	55	123.3	30	220	90	F07(70)	14	10	38	85	8.5
150	204	140	56	155.6	30	220	90	F07(70)	14	10	38	85	14.6
200	238	173	61	202.5	40	265	125	F10(102)	17	12	48	100	20.6
250	270	210	66	250.5	40	350	125	F10(102)	22	12	44	100	34.8
300	315	234	77	301.5	40	350	125	F10(102)	22	12	44	100	46.9

## VTB200 Gearbox DN40-300

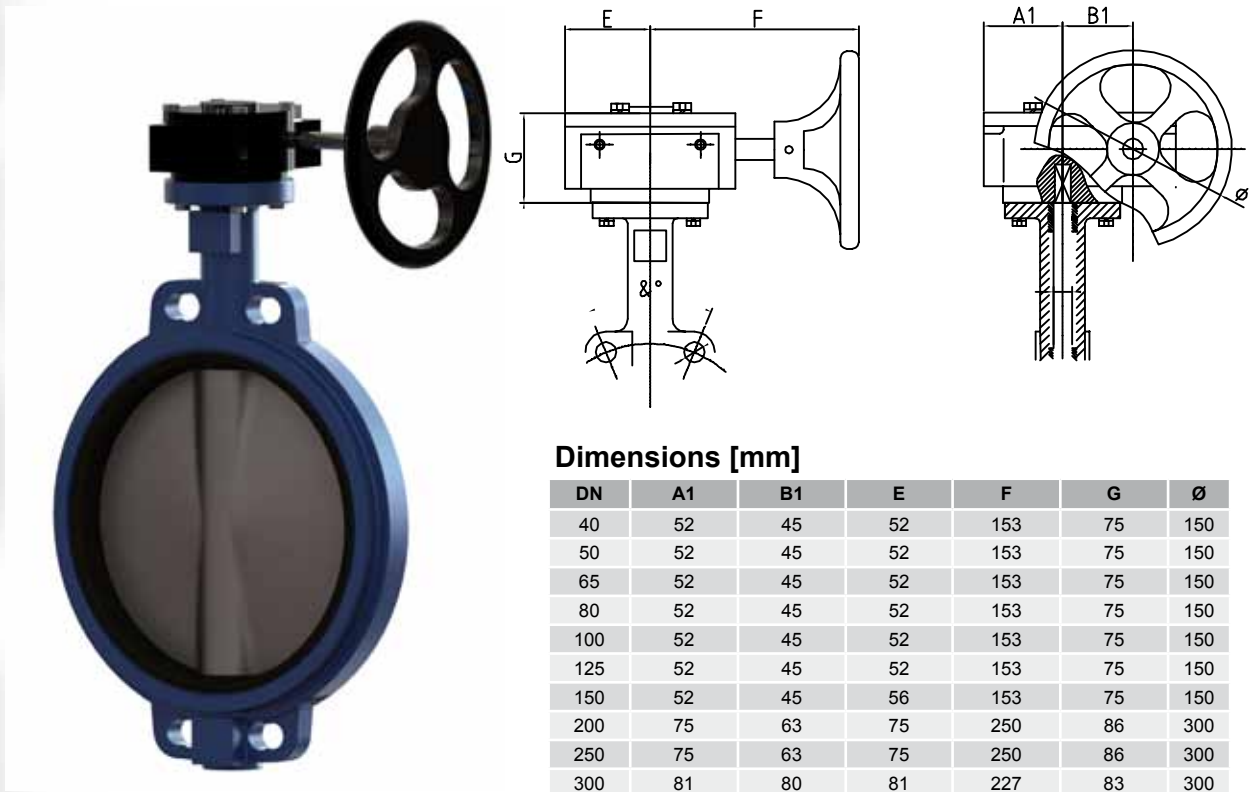

Dimensions [mm]

DN	A1	B1	E	F	G	Ø
40	52	45	52	153	75	150
50	52	45	52	153	75	150
65	52	45	52	153	75	150
80	52	45	52	153	75	150
100	52	45	52	153	75	150
125	52	45	52	153	75	150
150	52	45	56	153	75	150
200	75	63	75	250	86	300
250	75	63	75	250	86	300
300	81	80	81	227	83	300

## VTB200 DN350-DN450

### Materials

Item	Description	Materials
1	Body	GG25
2	Disc	304SS   316SS
3	Stem	416SS
4	Gearbox	Cast iron/Steel
5	Seat ring	EPDM or NBR
6	Bushing (5x)	PTFE-fiberglass
7	O-ring	EPDM
8	Pin	SS
9	Handwheel	Cast iron
10	Cover	GG25
11	Seal	EPDM
12	Bolt	Steel
13	Bolt	Steel





# VTB200 Wafer DN350-DN450

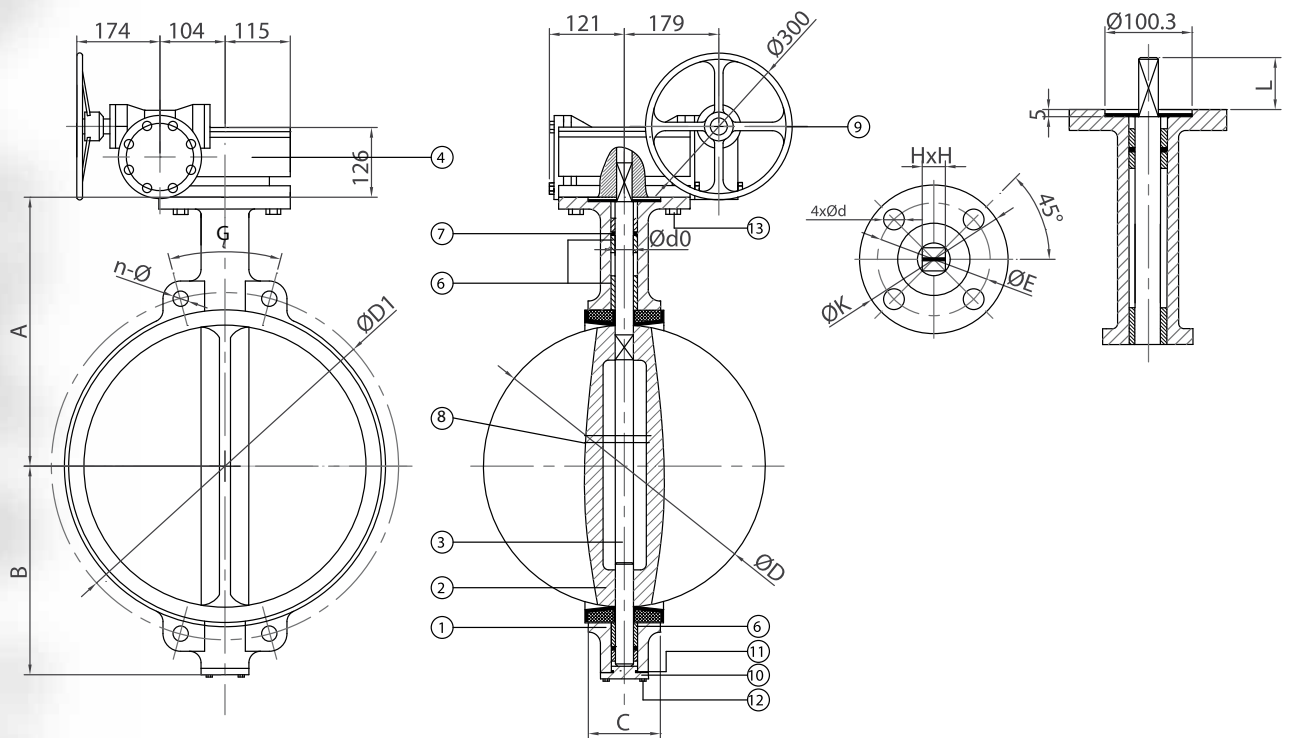

## Dimensions [mm]

DN	A	B	C	D	L	K	E	G	H	Weight [kg] including Gearbox
350	368	267	78	333.3	45	140	F10(102)	22.5°	22	56
400	400	309	86.5	389.6	50	197	F14(140)	22.5°	27	93
450	422	328	103.6	440.5	50	197	F14(140)	22.5°	27	113

  

PN10			PN16		ASA 150	
DN	n- $\varnothing$	D1	n- $\varnothing$	D1	d1	D1
350	4 x 22	460	4 x 26	470	4 x 28.4	476,2
400	4 x 26	515	4 x 30	525	4 x 28.4	539.7
450	4 x 26	565	4 x 30	585	4 x 31.8	577.8

# VTB200 Monoflange DN500-DN1200

## Materials

Item	Description	Materials
1	Body	GG25
2	Disc	304SS
3	Stem	416SS
4	Gearbox	Cast iron/Steel
5	Seat ring	EPDM or BUNA
6	Bushing	PTFE-fiberglass
7	O-ring	EPDM
8	Pin	SS
9	Pin	Steel
10	Cover	GG25
11	Seal	EPDM
12	Bolt	Steel
13	Bolt	Steel
14	Handwheel	Cast iron

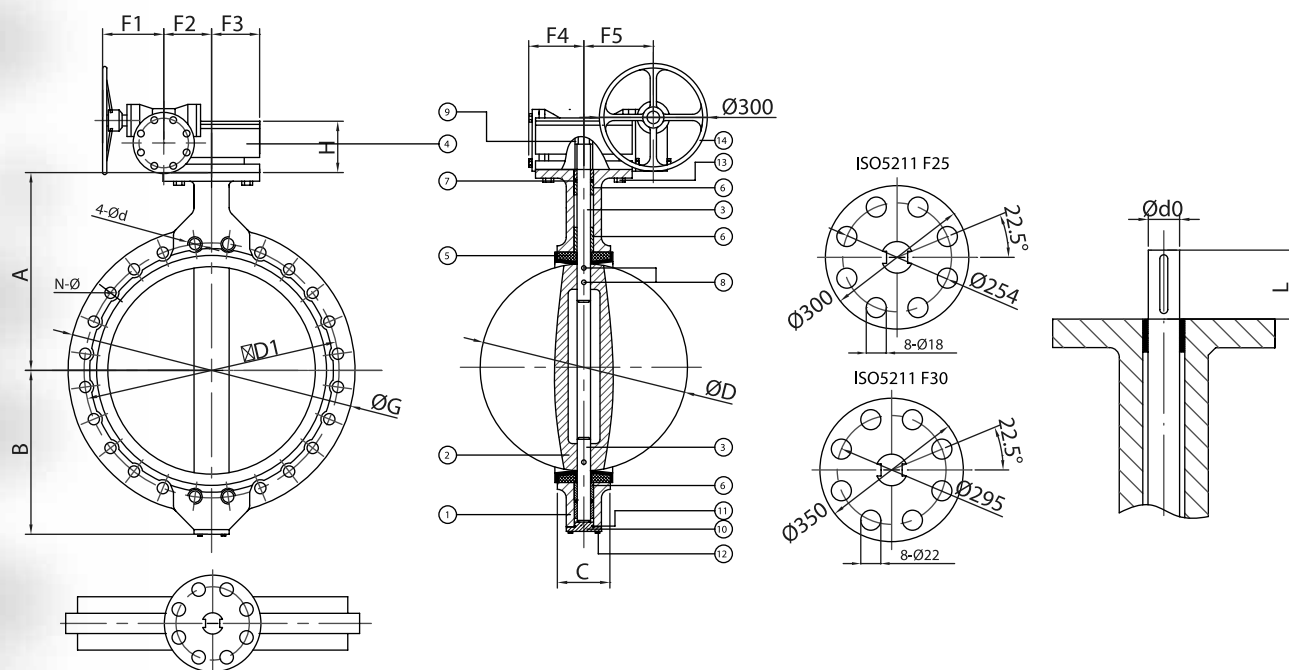



# VTB200 DN700-DN1200

## Dimensions [mm]

DN	A	B	C	D	L	ØG	H	ISO	d0	F1	F2	F3	F4	F5	Weight [kg] including Gearbox
500	480	361	127	491.6	65	650	146	F14	36x36	174	130	144	142	198	176
600	562	459	152	592.5	70	840	146	F16	22	174	130	144	142	198	241
700	624	520	167	695	100	895	157	F25	18	165	162	189	183	244	361
750	660	539	167	744.4	110	984	157	F25	18	165	162	189	183	244	407
800	672	591	188	794.7	110	1015	157	F25	18	165	162	189	183	244	445
900	720	656	203	865	118	1115	235	F25	18	215	196	220	215	270	831
1000	800	721	216	965	142	1230	235	F25	18	215	196	220	215	270	982
1200	941	864	276	1160.6	154	1511	310	F30	22	215	295	214	310	458	1530

DN	PN10			PN16		
	N-Ø	4-Ød	D1	N-Ø	4-Ød	D1
500	20-28	4-M24	620	20-28	4-M30	650
600	16-30	4-M27	725	16-36	4-M33	770
700	20-30	4-M27	840	20-36	4-M33	840
750	20-33	4-M30	900	20-36	4-M33	900
800	20-33	4-M30	950	20-39	4-M36	950
900	24-33	4-M30	1050	24-39	4-M36	1050
1000	24-36	4-M33	1160	24-42	4-M39	1170
1200	28-39	4-M36	1380	24-48	4-M45	1390

# VTB200 DN32/40-300

## Dimensions [mm]

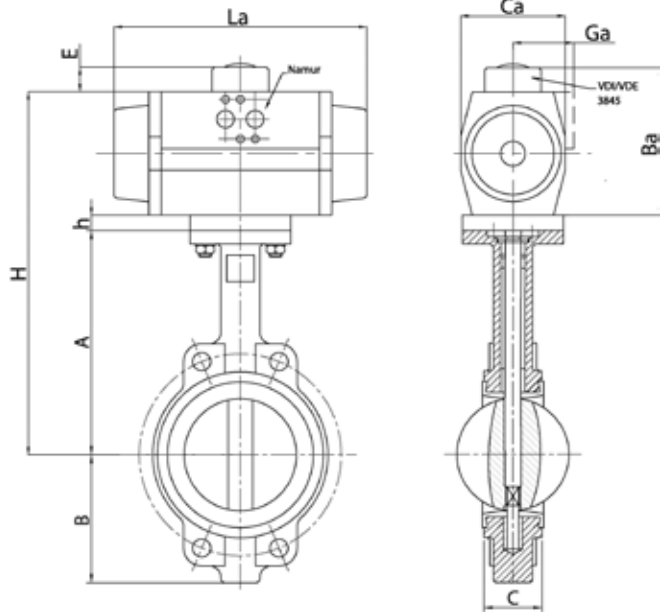

### With double acting pneumatic Actuator

DN	DW	h	La	Ba	Ca	Ga	H	E	Weight [kg]
32/40	AP1D	24	137	87	60	41	221	20	4,1
50	AP2D	22	150	103	73	44.5	245	20	4,8
65	AP2D	22	150	103	73	44.5	256	20	5,9
80	AP3D	17	204	120	85	49.5	296	20	8,4
100	AP3D	17	204	120	85	49.5	315	20	10,5
125	AP3.5D	17	230	130	98	53	338	20	12,8
150	AP4D	17	271	145	110	58	366	20	20,4
200	AP4.5D	22	305	172	128	69	398	30	28,9
250	AP5D	25	360	185	140	-	480	30	32,2
300	AP5.5D	22	380	206	160	-	543	30	61,1

### With single acting Actuator

DN	EW	h	La	Ba	Ca	Ga	H	E	Weight [kg]
32/40	AP2S	24	150	103	73	44.5	257	20	4,8
50	AP3S	17	204	120	85	49.5	277	20	6,6
65	AP3.5S	15	230	130	98	53	297	20	9,2
80	AP3.5S	15	230	130	98	53	323	20	10,5
100	AP4S	15	271	145	110	58	338	20	14,6
125	AP4.5S	14	305	172	128	69	390	30	18,2
150	AP5S	14	360	185	140	-	403	30	28,8
200	AP6S	22	462	230	175	-	490	30	46,5
250	AP8S	15	555	300	215	-	585	50	69,2
300	AP8S	15	555	300	215	-	630	50	95,5

Actuator are sized with an air pressure of 6 barg and a clean media. Medium pressure 6 barg

# VTB200 DN350-DN600

## Dimensions [mm]

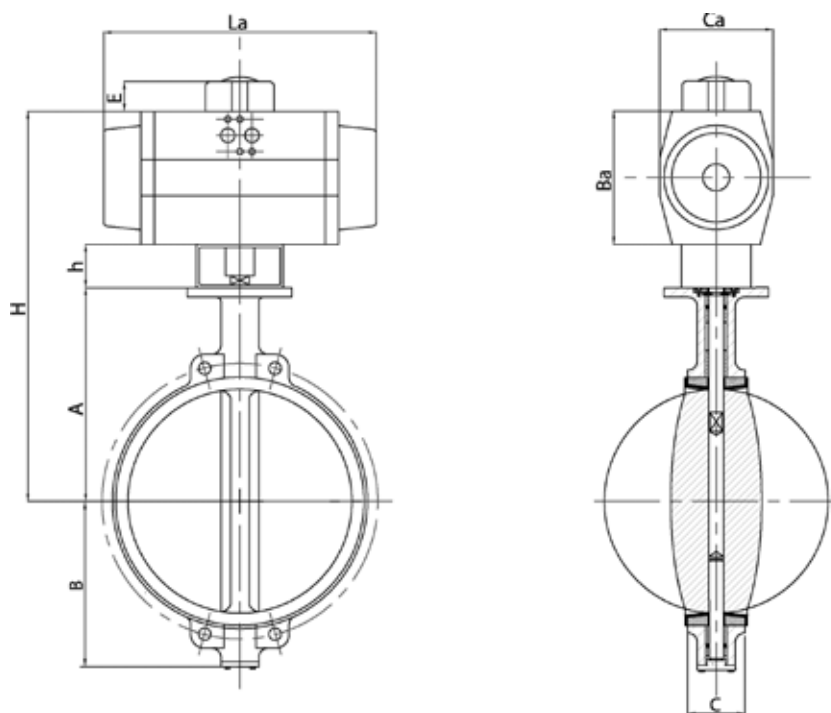

### With double acting pneumatic Actuator

DN	DW	h	La	Ba	Ca	H	E	Weight [kg]
350	AP5.5D	100	388	422	160	890	30	70
400	AP6D	120	468	500	175	1020	30	119
450	AP8D	120	563	612	215	1154	50	154
500	AP8D	120	563	612	215	1212	50	216
600	AP10D	140	750	838	290	1540	50	346

### With single acting pneumatic Actuator

DN	EW	h	La	Ba	Ca	H	E	Weight [kg]
350	AP8S	120	563	612	215	1100	50	104
400	AP10S3	140	750	838	290	1378	50	221
450	AP10S4	140	750	838	290	1400	50	241
500	AP10S	140	750	838	290	1458	50	304
600	AP10S6	140	750	838	290	1540	50	364

Actuator are sized with an air pressure of 6 barg and a clean media. Medium pressure 6 barg.

#### Remark:

S without means 5 Springs on each side of the actuator.

S3 means 3 springs on each side; S4 means 4 springs on each side, etc..

# Assembly and disassembly instructions

## Montage

1. Connect the body (1) of the valve to a clamp from the bottom side.
2. Mount the seat (2) in the body (1). according to the holes. Align the bigger hole on the top of the flange of the body (1).
3. Mount the O-ring (4) and the bushing (5) to the body.
4. Insert the stem (6) in the body (1) through the top flange, till the stem (6) is equal to the upper hole of the seating (2).
5. Mount the disc (3) in the seating (2). and press the stem down through the disc.
6. Mount the circlip (7) on top of the stem (6).
7. Attach the stopper plate (8) and screw it to the top flange using the bolts (12).
8. Tighten the sector plate (10) with the bolts and nuts (12) (do not tighten these complete).
9. Mount the lever (13) on the stem (6) and position the sector plate (10) at the same time.
10. Tighten bolts and nuts (12) and tighten the lever to the stem with the bolt (14).
11. The butterfly valve is ready for installation between flanges.

## Disassembly

1. Connect the valve body (1) to a clamp from the bottom side.
2. If the valve is lever operated, loosen the bolt (14) and remove the lever (13).
3. Loosen the bolts and nuts (12), dismantel the sector plate (10).
4. If any type of actuator is used, remove this first from the valve.
5. Remove the screws (9) and the stopper plate (8).
6. Disconnect the valve body (1) from the clamp to remove the stem (6).
7. Secur the body to the clamp from the square side of the valve (1).
8. Remove the stem (6) from the body after that the disc (3) and the seating (2).

## Removing the valve from the pipeline

1. Stop the flow of the fluid and discharge the fluit form the pipeline.
2. Shut the valve 100%
3. Loosen and remove all the bolts which prevent removing the valve from the pipeline.
4. Remove the valve by opening the space between the flanges.(if needed use an seperator to remove the valve)

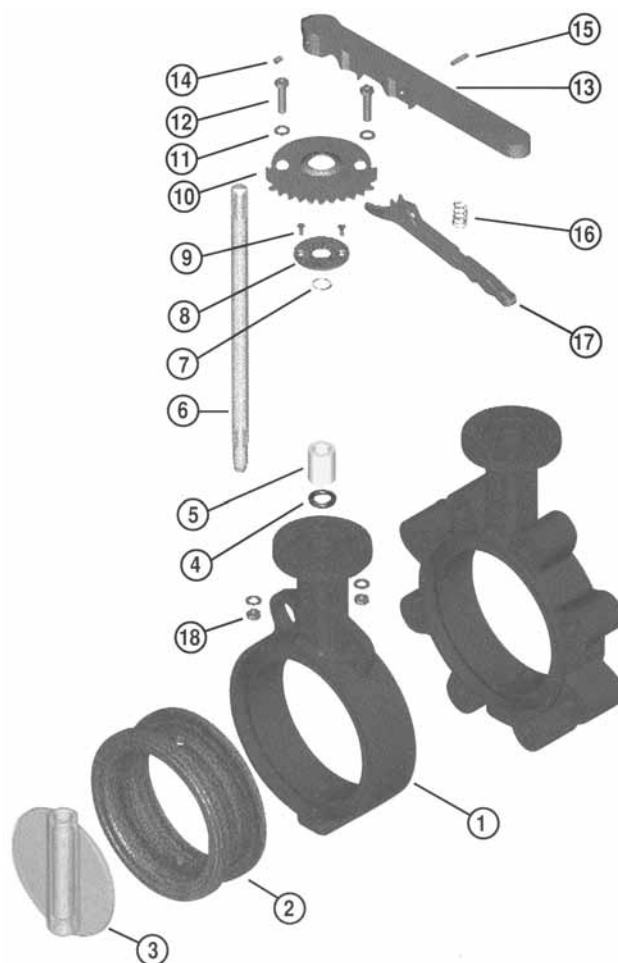

# Installation instructions

## Installing the valves in existing pipelines

1. In order to make mounting easier open the flanges completely. If needed with an separator
2. Disc must be in a 95% closed position.
3. Centre the valve between the flanges and tighten the bolts and nuts, fix these by hand.
4. Open the valve completely and remove the flange separator between the flanges.
5. Tighten the bolts again using hand only.
6. After that open and close the valve several times to ensure a free movement of the valve.
7. Tighten the bolts and nuts until the flanges touch the body of the valve.

## Installing the valve in a new pipeline

1. Connect the valve with bolts between the two flanges in the pipeline while the disc is in a 95% closed position.
2. Weld the flange of the line only at two points.
3. Remove the valve, make sure that the seating stays in a good condition.
4. Carefully weld the flange on the line and wait for cooling. To avoid heat damage to the rubber seat. Never weld the flange while the valve is still connected.
5. Using welding gauge apparatus is advised for valves with sizes over DN 200.
6. Mount the butterfly valve ( 95% closed) between the flanges with bolts and nuts.
7. Tighten the bolts using hand only.
8. Open and close the valve several times to ensure an free movement. Tighten the bolts and nuts until the flanges touch the body of the valve.

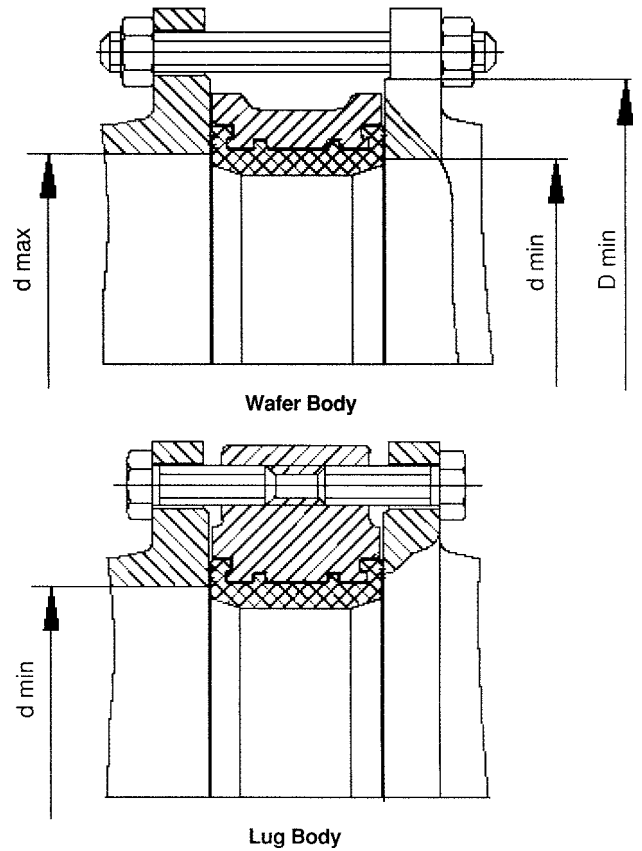

[mm]

DN	50	65	80	100	125	150	200	250	300	350	400	450	500	600
Ød min/ d max	52/62	68/77	82/95	102/118	127/144	152/170	202/225	252/276	303/325	316/356	375/407	415/450	468/505	545/600
ØD min	88	104	120	146	176	200	256	310	368	405	455	500	560	655

# Additional installation information

Installing the valves near the curves (see diagram) shall cause turbulence and should be avoided.

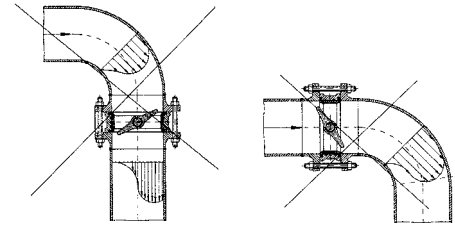

Welded neck type flanges are advised. Otherwise the valves must be centred between the flanges.

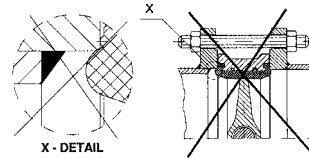

Always install the valves further from the curve equally 3 to 5 times the diameter of the line. The axis of the stem should be parallel to the line extended from the opposite side of the curve.

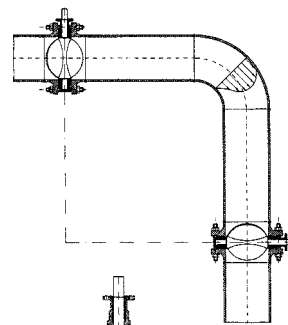

Surrounding space must be provided between the flanges to insert the valve. The disc must be at 95% closed position prior to installing the valve.

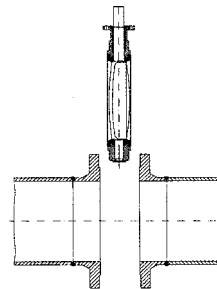

Using scrap pipes is not recommended. The pipes must not be welded to each other at short intervals. The lines connected to the two sides of the valve must be on the same axis to prevent leakage.

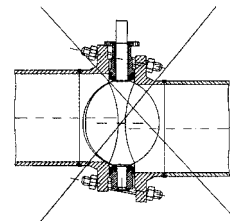

- lines connected to the valves must be centred with each other.
- movement of the disc must be completely open.
- line and stem axis must be centred.
- the bolts must be tightened until the flanges touch the valve body.

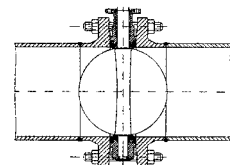

If the stem must be installed parallel to the ground to accommodate dense flowing materials, lower part of the disc should open in the same direction of the flow.

